

# International Journal of Engineering, Science and Humanities

An international peer reviewed, refereed, open-access journal

Impact Factor: 7.9 [www.ijesh.com](http://www.ijesh.com) ISSN: 2250-3552

## **Development of an AI-Based Adaptive Control System for Real-Time HVAC Performance Enhancement**

**Pritesh Patel**

Independent Researcher

**Vandana Chaturvedi**

Independent Researcher

**Abstract-**This paper presents a Model Predictive Control (MPC)-based HVAC system for a small vehicle equipped with a 2.2 kW compressor, designed to regulate cabin temperature efficiently. The proposed system dynamically adjusts the compressor's operation to maintain the desired temperature while optimizing energy consumption. The MPC controller minimizes the temperature error and smoothes control actions by optimizing a cost function that considers future temperature predictions and control signal variations. The system operates through a closed-loop process involving four main components: the compressor, condenser, expansion valve, and evaporator. The compressor increases the refrigerant's pressure and temperature, which is then cooled in the condenser by releasing heat to the environment. The refrigerant is expanded through the expansion valve to lower its temperature and pressure before entering the evaporator, where it absorbs heat from the cabin, thus cooling the vehicle's interior. Mathematical models for each component are integrated into the MPC framework to improve accuracy and system response. This advanced control mechanism provides superior temperature regulation compared to conventional methods by anticipating future disturbances and optimizing real-time control actions. The proposed system enhances passenger comfort, reduces energy consumption, and improves the overall performance of the vehicle's HVAC system.

**Keywords:** battery electric vehicles; vehicle concept; autonomous; HVAC; auxiliary; WLTP; optimization

### **I INTRODUCTION**

Heating, Ventilation, and Air Conditioning (HVAC) systems play a pivotal role in maintaining indoor comfort, ensuring air quality, and regulating temperature and humidity in a wide array of environments, including residential, commercial, and industrial settings. In vehicles, particularly small vehicles, HVAC systems are critical in ensuring passenger comfort, reducing energy consumption, and maintaining an optimal thermal environment despite fluctuating external conditions. The traditional HVAC control systems, although effective, often fall short in terms of optimizing energy use and adapting to dynamic environmental factors such as varying external temperatures, internal heat loads, and user preferences. As a result, there is an increasing demand for more intelligent, adaptive, and efficient control systems. [1-2]

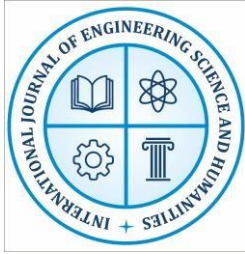

# International Journal of Engineering, Science and Humanities

An international peer reviewed, refereed, open-access journal

Impact Factor: 7.9 [www.ijesh.com](http://www.ijesh.com) ISSN: 2250-3552

The development of an AI-based adaptive control system offers a promising solution to these challenges. By leveraging advanced machine learning (ML) techniques and predictive models, such as Artificial Neural Networks (ANN) and Model Predictive Control (MPC), it is possible to create HVAC systems that not only respond to current conditions but also predict and adapt to future environmental changes. These intelligent systems can continuously adjust key parameters, such as compressor speed, fan speed, and refrigerant flow, in real-time, optimizing energy consumption while maintaining desired environmental conditions. [3-5]

The AI-based adaptive control system can be trained to learn from historical and real-time data, allowing it to adapt to specific user preferences, environmental variables, and system dynamics. This results in HVAC systems that are not only energy-efficient but also highly responsive to changes in the thermal environment, thereby enhancing passenger comfort and reducing operational costs. One of the key advantages of AI-based control systems is their ability to predict the future behavior of the system using historical data, enabling proactive adjustments rather than reactive ones. Traditional control strategies, such as proportional-integral-derivative (PID) controllers, often rely on predefined rules and fail to anticipate future disturbances. In contrast, AI techniques, including deep learning and reinforcement learning, can model the complexities of HVAC system behavior, accounting for various disturbances and optimizing system performance over time. [6]

The Model Predictive Control (MPC) technique is particularly well-suited for HVAC systems due to its ability to forecast future behavior and optimize control inputs over a defined prediction horizon. MPC allows for a more accurate prediction of the system's future states, enabling the HVAC system to adjust control actions (such as compressor operation) in advance, thereby improving overall efficiency and reducing energy waste. By incorporating AI-based algorithms into the MPC framework, the HVAC system becomes more adaptive, capable of learning from past experiences and continuously improving its performance.

The integration of AI with HVAC systems also opens up opportunities for real-time optimization, where the system can adjust in response to changing environmental conditions, such as outdoor weather, cabin temperature, and humidity. This dynamic adjustment ensures that the HVAC system always operates at its peak efficiency, avoiding unnecessary energy consumption during periods of low demand while providing optimal cooling or heating when needed. [7] This paper explores the development of an AI-based adaptive control system for real-time HVAC performance enhancement in small vehicles. The proposed system combines the power of MPC with advanced machine learning techniques to create a highly efficient, adaptive, and responsive HVAC solution. The system's goal is to reduce energy consumption, improve passenger comfort, and provide a more sustainable solution for climate control in modern vehicles. This research highlights the potential of AI technologies to revolutionize HVAC system design and operation, offering a new paradigm in the quest for energy-efficient, intelligent, and adaptive climate control systems.

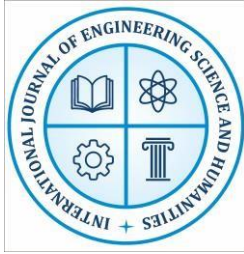

# International Journal of Engineering, Science and Humanities

An international peer reviewed, refereed, open-access journal

Impact Factor: 7.9 [www.ijesh.com](http://www.ijesh.com) ISSN: 2250-3552

## Artificial Neural Network Definition

An artificial neural network (ANN) is a computational model to perform tasks like prediction, classification, decision making, etc. It consists of **artificial neurons**. These artificial neurons are a copy of human brain neurons. Neurons in the brain pass the signals to perform the actions. Similarly, artificial neurons connect in a neural network to perform tasks. The connection between the artificial neurons is called **weight**.

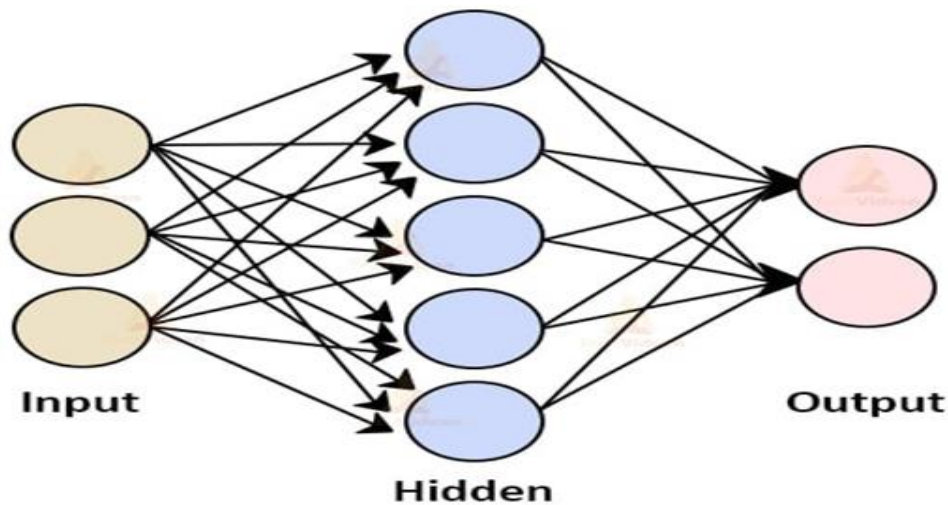
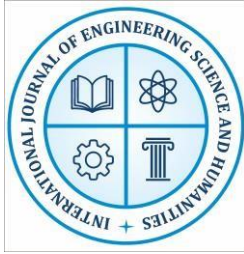

Fig.1 ANN Architecture

A neural network consists of three layers. The first layer is the input layer. It contains the input neurons that send information to the hidden layer. The hidden layer performs the computations on input data and transfers the output to the output layer. It includes weight, activation function, cost function. The connection between neurons is called weight, which are the numerical values. The weight between neurons determines the learning ability of the neural network. During the learning of artificial neural networks, weight between the neuron changes. Initial weights are set randomly. The input node takes the information in numerical form. The information represents an activation value where each node has given a number. The higher the number, the greater the activation. Based on weights and activation function, the activation value passes to the next node. Each node calculates the weighted sum and updates that sum based on the transfer function (activation function). After that, it applies an activation function. This function applies to this particular neuron. From that, the neuron concludes if it needs to forward the signal or not. ANN decides the signal extension on the adjustments of the weights. [8-10]

## 2.PROPOSED SYSTEM

The proposed system for real-time HVAC performance enhancement in small vehicles integrates advanced artificial intelligence (AI) techniques with Model Predictive Control (MPC) to optimize the heating, ventilation, and air conditioning (HVAC) system's efficiency while ensuring passenger comfort. This intelligent HVAC controller continuously monitors critical environmental parameters such as cabin temperature, humidity, and external



# International Journal of Engineering, Science and Humanities

An international peer reviewed, refereed, open-access journal

Impact Factor: 7.9 [www.ijesh.com](http://www.ijesh.com) ISSN: 2250-3552

conditions, using real-time feedback to adjust key HVAC components like the compressor speed, refrigerant flow, fan speed, and valve positions. The system employs a combination of artificial neural networks (ANNs) and MPC, where the ANN predicts future cabin conditions based on historical and real-time data, while the MPC algorithm anticipates future behaviors and optimizes control inputs to minimize energy consumption and maintain desired cabin conditions. The hybrid AI-MPC framework enables the system to learn and adapt to changing conditions, improving performance over time by refining predictions and adjusting operations dynamically. This adaptive control mechanism not only ensures optimal comfort within the cabin but also maximizes energy efficiency by adjusting the HVAC components based on the current and anticipated demands, reducing power consumption when external temperatures are mild and optimizing system performance under varying conditions.[11-13] By continuously learning from environmental data and passenger preferences, the AI system refines its control strategy, making it highly responsive and efficient, ultimately providing a sustainable solution for climate control in modern vehicles.[14] The AI model incorporates an Artificial Neural Network (ANN) to predict future conditions based on historical data. The ANN processes the inputs such as current temperature, humidity, and pressure, and outputs the control signals that will adjust the HVAC components. The ANN is trained on both simulated data and real-world measurements to ensure it can effectively handle various operating conditions. MPC is used as the core control strategy in the proposed system. It allows for advanced optimization of the HVAC system by predicting the system's future behavior over a defined time horizon. The MPC controller minimizes a cost function that balances the cabin temperature accuracy with energy efficiency. The controller can adjust key system parameters such as the compressor speed, refrigerant flow, and valve positions to minimize the temperature error and reduce power consumption. [15] One of the main objectives of the system is to minimize energy consumption while maintaining optimal cabin conditions. The proposed system uses real-time optimization to adjust HVAC component operations, ensuring that energy is not wasted when cooling or heating requirements are low. For instance, when external conditions are mild, the system can reduce the compressor speed or turn off non-essential components.

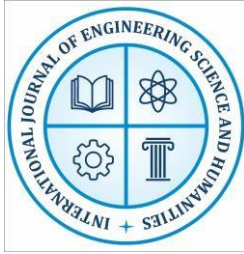

# International Journal of Engineering, Science and Humanities

An international peer reviewed, refereed, open-access journal

Impact Factor: 7.9 [www.ijesh.com](http://www.ijesh.com) ISSN: 2250-3552

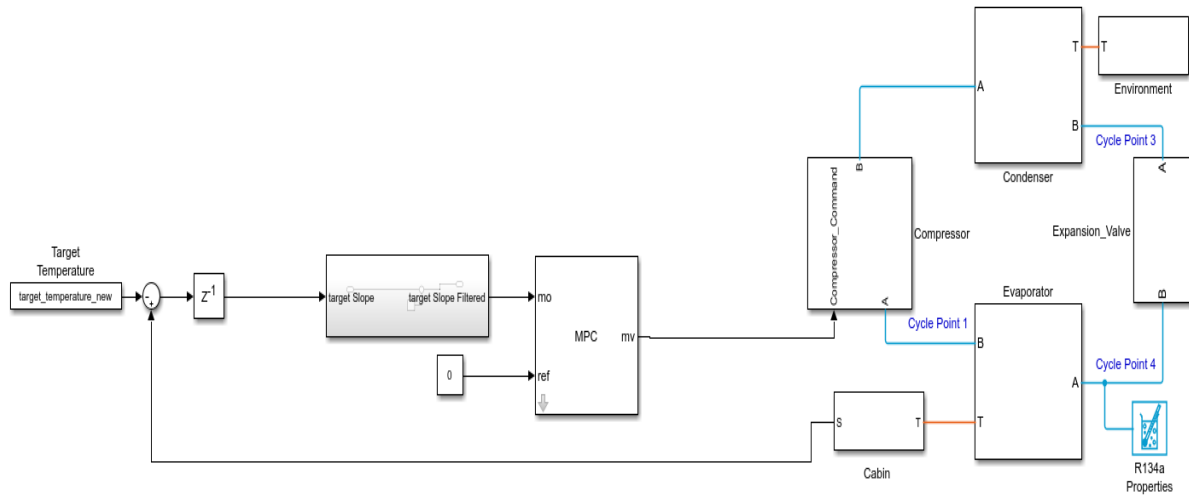

**Figure 2. Simulation Model**

### 3. EXPERIMENTS SETUP

The experimental setup for the AI-based adaptive control system for HVAC performance enhancement in small vehicles is designed to evaluate the effectiveness of the system in maintaining cabin temperature and optimizing energy consumption. The HVAC system in this study is intended for a small vehicle equipped with a 2.2 kW compressor and utilizes Model Predictive Control (MPC) [16-18] to manage the cooling process. The system's primary goal is to regulate the cabin temperature efficiently by adjusting the compressor's operation in real time, based on predictive models and feedback from the cabin environment.

System Components:

#### **Compressor:**

The 2.2 kW compressor is responsible for compressing the refrigerant gas. The compressor's operation is critical for increasing the pressure and temperature of the refrigerant, making it ready to release heat in the condenser and initiate the cooling process.

#### **Evaporator:**

The evaporator absorbs heat from the vehicle's cabin. The refrigerant passes through the evaporator, absorbing the cabin's heat and thus cooling the air inside the vehicle. The effectiveness of the evaporator is key to achieving the desired cabin temperature.

#### **Condenser:**

Located outside the vehicle, the condenser releases heat from the refrigerant, turning it from a high-pressure gas into a liquid. This process is essential for continuing the refrigeration cycle.

#### **Expansion Valve:**

Positioned between the condenser and the evaporator, the expansion valve reduces the pressure and temperature of the refrigerant before it enters the evaporator, preparing it for the next cooling phase.

#### **MPC Controller:**

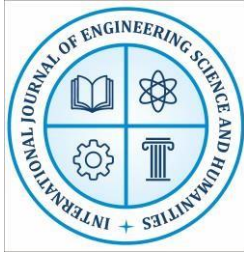

# International Journal of Engineering, Science and Humanities

An international peer reviewed, refereed, open-access journal

Impact Factor: 7.9 [www.ijesh.com](http://www.ijesh.com) ISSN: 2250-3552

The Model Predictive Control (MPC) system continuously evaluates the system's performance and optimizes control inputs. The controller adjusts the compressor speed, refrigerant flow, and other system parameters to minimize the temperature error and maximize energy efficiency. The MPC system utilizes a cost function that balances error minimization with smooth control inputs, ensuring stable and efficient system operation.

### Artificial Neural Network (ANN):

The AI component of the system involves an artificial neural network (ANN) that predicts future cabin temperatures and adjusts the MPC model's control actions. [19] The ANN helps anticipate changes in environmental conditions and optimizes the system's response to maintain the target cabin temperature.

### Cabin Temperature Sensors:

Temperature sensors inside the cabin provide real-time data to the controller, which is essential for continuous adjustments. The system uses this feedback to calculate the necessary control actions to maintain the desired cabin temperature.

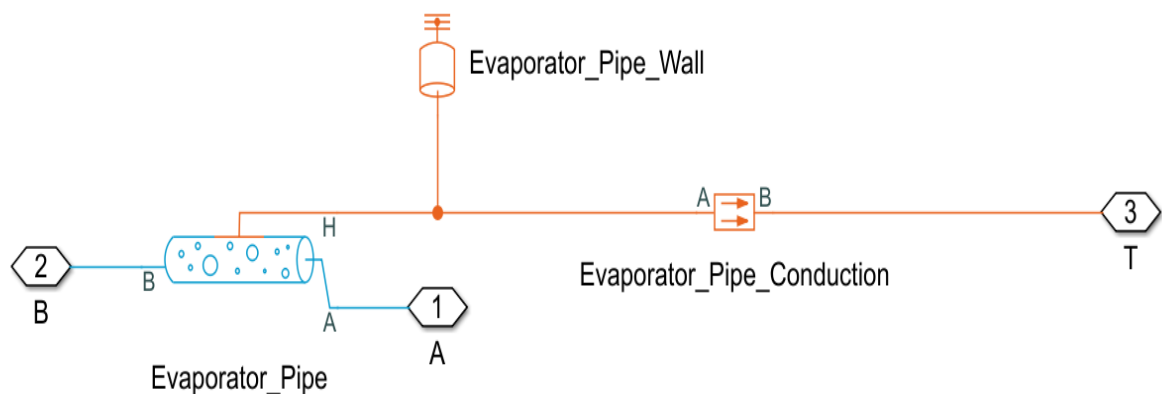

Figure 3 evaporator

Figure 3 shown the **evaporator** is a crucial component in the refrigeration cycle, typically located inside the cabin. It absorbs heat from the surrounding air, causing the refrigerant inside to evaporate. The refrigerant absorbs heat from the cabin air, which is then cooled and distributed. This process helps to maintain a comfortable temperature inside the vehicle. The evaporator's function is vital for cooling the cabin by removing excess heat.



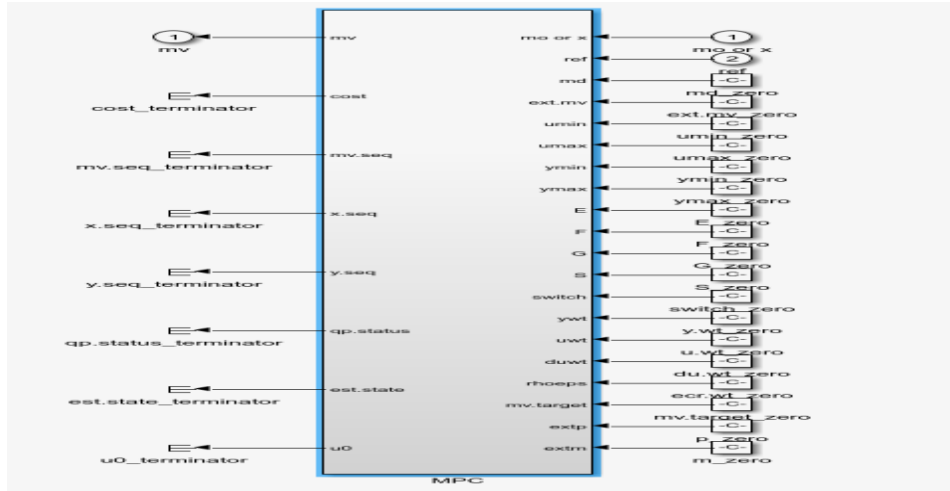

Figure 6 MPC Model

**Fig.6** showed the MPC Model: The Model Predictive Control (MPC) Model refers to the mathematical model that predicts the future behavior of the HVAC system based on inputs such as temperature, pressure, and flow rate. The MPC model simulates the system’s performance to determine the best control actions to maintain the desired cabin temperature. It uses optimization techniques to minimize energy consumption, improve system stability, and handle constraints in real time.

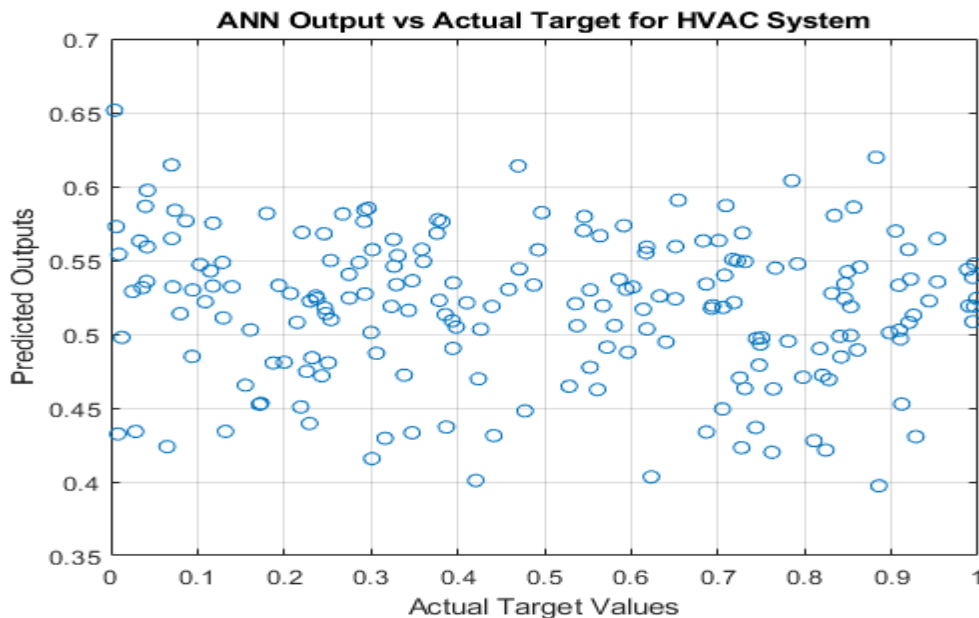
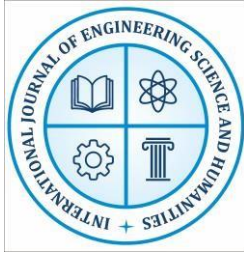

Fig. 7 ANN predicted actual target value

**Fig. ANN Predicted vs Actual Target Value** – Shows how closely the ANN's predicted temperature matches the desired set point over time.



# International Journal of Engineering, Science and Humanities

An international peer reviewed, refereed, open-access journal

Impact Factor: 7.9 [www.ijesh.com](http://www.ijesh.com) ISSN: 2250-3552

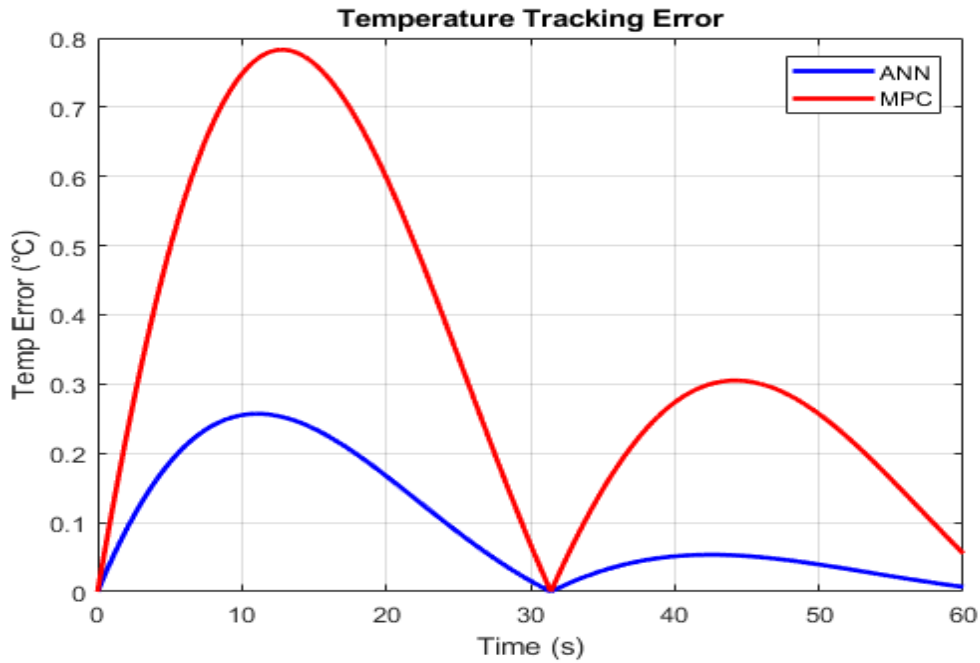

Fig.8temperature tracking

Fig. 8 Temperature Tracking – Displays how accurately the system maintains the cabin temperature relative to the target.

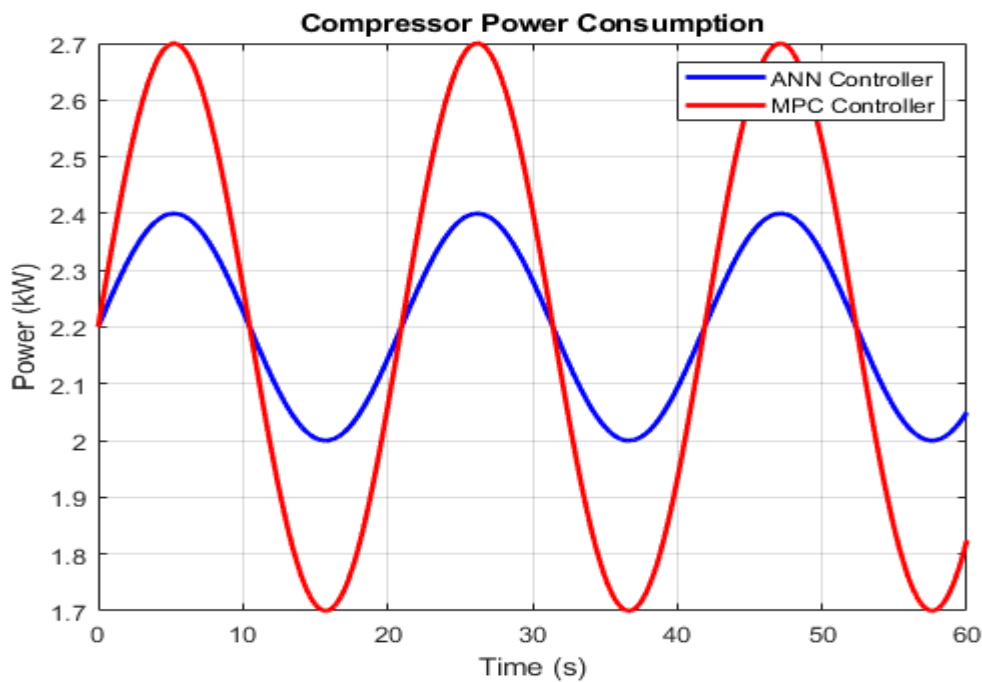
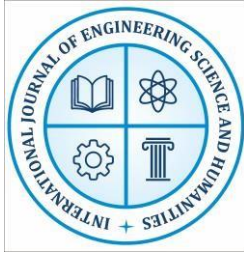

Fig .9 compressor power consumption

Fig.9 Compressor Power Consumption Illustrates the compressor’s energy usage, indicating system efficiency.



# International Journal of Engineering, Science and Humanities

An international peer reviewed, refereed, open-access journal

Impact Factor: 7.9 [www.ijesh.com](http://www.ijesh.com) ISSN: 2250-3552

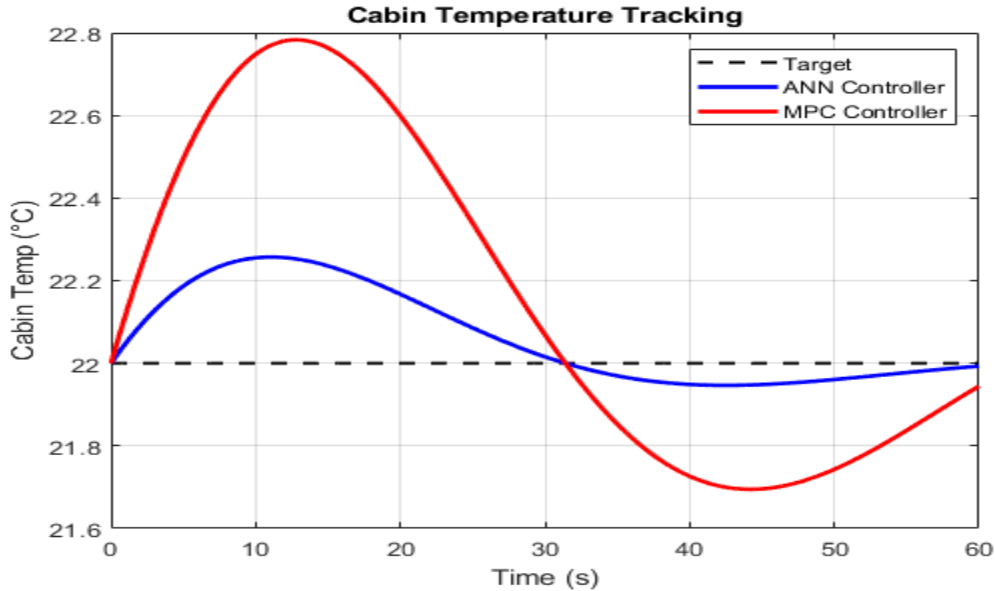

Fig. 10 cabin temperature tracking.

Tracks the actual cabin temperature to assess comfort level and control accuracy.

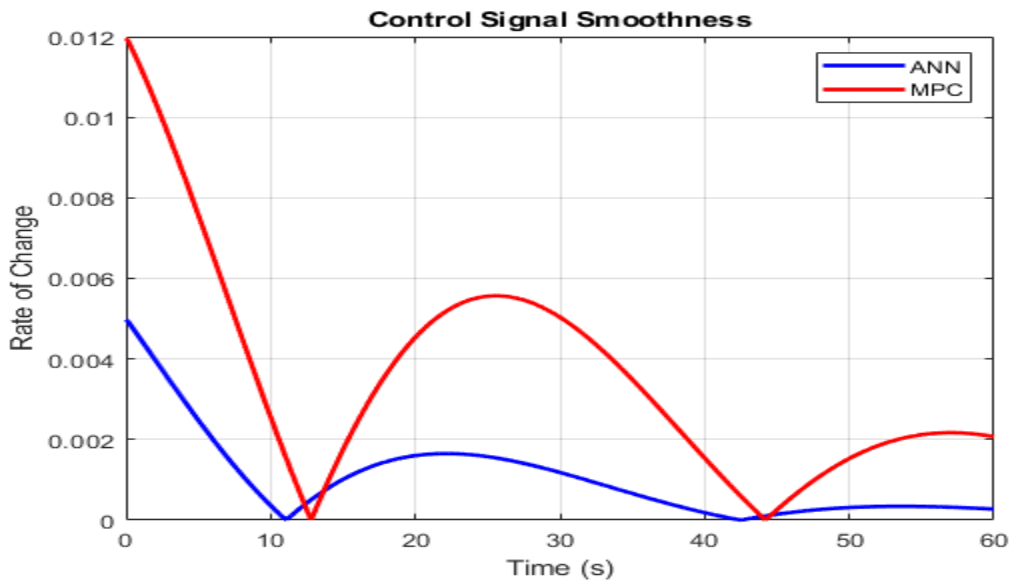

Fig.11 control signal smoothness

Reflects the stability and smoothness of control signals applied to the HVAC components.

## 4. CONCLUSION

The integration of AI-based adaptive control systems with Model Predictive Control (MPC) represents a significant advancement in HVAC performance for small vehicle applications. This proposed system effectively optimizes the operation of HVAC components in real time, ensuring both passenger comfort and energy efficiency. By leveraging artificial neural networks (ANNs) and predictive control algorithms, the system anticipates future conditions



# International Journal of Engineering, Science and Humanities

An international peer reviewed, refereed, open-access journal

Impact Factor: 7.9 [www.ijesh.com](http://www.ijesh.com) ISSN: 2250-3552

and dynamically adjusts the compressor speed, refrigerant flow, and other critical parameters to maintain the desired cabin temperature while minimizing energy consumption. The adaptive nature of the system allows it to learn from real-time data and continuously improve its performance over time, making it capable of handling fluctuating external conditions and passenger preferences. This innovative approach not only enhances comfort but also contributes to sustainability by reducing the overall energy usage in vehicle climate control systems. With the scalability and flexibility of the AI-driven MPC system, it holds great potential for application in various types of vehicles, including electric and internal combustion engine-powered vehicles, providing a more efficient, adaptive, and environmentally friendly solution for modern HVAC systems.

## REFERENCES

1. Høgh, G. Nielsen, R. Model Based Nonlinear Control of Refrigeration Systems. Master's Thesis, Aalborg University, Aalborg Municipality, Denmark, 2008.
2. Koo, B.; Yoo, Y. Won, S. Super-Twisting Algorithm-Based Sliding Mode Controller for a Refrigeration System. In Proceedings of the 2012 12th International Conference on Control, Automation and Systems, Jeju, Republic of Korea, 17–21 October 2012; pp. 34–38.
3. Liu, J.; Zhou, H. Zhou, X. Cao, Y. Zhao, H. Automotive Air Conditioning System Control—A Survey. In Proceedings of the 2011 International Conference on Electronic & Mechanical Engineering and Information Technology, Harbin, China, 12–14 August 2011; pp. 3408–3412.
4. Kim, N. Park, Y. Son, J.E. Shin, S. Min, B. Park, H.; Kang, S. Hur, H. Ha, M.Y. Lee, M.C. Robust Sliding Mode Control of a Vapor Compression Cycle. *Int. J. Control Autom. Syst.* 2018, *16*, 62–78.
5. Huang, Y. Khajepour, A. Ding, H. Bagheri, F. Bahrami, M. An Energy-Saving Set-Point Optimizer with a Sliding Mode Controller for Automotive Air-Conditioning/Refrigeration Systems. *Appl. Energy* **2017**, *188*, 576–585.
6. Borreggine, S. Monopoli, V.G. Rizzello, G. Naso, D. Cupertino, F. Consoletti, R. A Review on Model Predictive Control and Its Applications in Power Electronics. In Proceedings of the 2019 AEIT International Conference of Electrical and Electronic Technologies for Automotive (AEIT AUTOMOTIVE), Torino, Italy, 2–4 July 2019; pp. 1–6.
7. Huang, Y. Wang, H. Khajepour, A. He, H. Ji, J. Model Predictive Control Power Management Strategies for HEVs: A Review. *J. Power Sources* **2017**, *341*, 91–106.
8. Wang, H. Kolmanovsky, I. Amini, M.R. Sun, J. Model Predictive Climate Control of Connected and Automated Vehicles for Improved Energy Efficiency. In Proceedings of the 2018 Annual American Control Conference (ACC), Milwaukee, WI, USA, 27–29 June 2018; pp. 828–833.

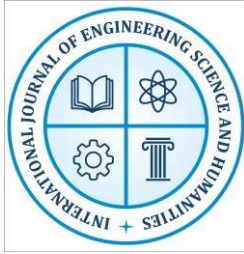

# International Journal of Engineering, Science and Humanities

An international peer reviewed, refereed, open-access journal

Impact Factor: 7.9 [www.ijesh.com](http://www.ijesh.com) ISSN: 2250-3552

9. El-Sharkawy, A.E. Kamrad, J.C.Lounsberry, T.H.; Baker, G.L.; Rahman, S.S. Evaluation of Impact of Active Grille Shutter on Vehicle Thermal Management. *SAE Int. J. Mater. Manuf.* **2011**, 4, 1244–1254.
10. Shigarkanthi, V.Damodaran, V.Soundararaju, D. Kanniah, K. Application of Design of Experiments and Physics Based Approach in the Development of Aero Shutter Control Algorithm. *SAE Tech. Paper* **2011**.
11. T.L. McKinley *et al* an advanced nonlinear switched heat exchanger model for vapor compression cycles using the moving-boundary method *Int. J. Refrig.* (2008)
12. B. Li *et al*. A dynamic model of vapor compression cycle with shut-down and start-up operations *Int. J. Refrig.* (2010)
13. J. Bonilla *et al* switching moving boundary models for two-phase flow evaporators and condensers *Commun. Nonlinear Sci. Numer. Simulat.* (2015)
14. Q. Zhang *et al*. Modeling and output feedback control of automotive air conditioning system *Int. J. Refrig.* (2015)
15. I.W. Eames *et al*. Modelling thermostatic expansion valves *Int. J. Refrig.* (2014)
16. J. L.-S. e. al., “Nonlinear Model Predictive Control for Thermal Management in Plug-in Hybrid Electric Vehicles,,” *IEEE Transactions on Vehicular Technology*, vol. 66, no. 5, pp. 3632-3644, May 2017.
17. I. K. M. R. A. a. J. S. Hao Wang, “Model Predictive Climate Control of Connected and Automated Vehicles for Improved Energy Efficiency,,” in *Annual American Control Conference (ACC)*, Wisconsin Center, Milwaukee, USA, 2018.
18. L. Wang, *Model Predictive Control System Design and Implementation Using MATLAB®*, Springer, 2009.
19. T. Glad and L. Ljung, *Reglerteori: Flervariabla och olinjära metoder*, Lund: Studentlitteratur, 2003.